



**Section A*****Bahagian A***

[36 marks]

*[36 markah]*

Answer **all** the questions. Write your answers in the space provided on the **Answer Sheet**. Each answer carries **one** mark.

*Jawab semua soalan. Tulis jawapan anda di ruang yang disediakan pada **Helaian Jawapan**. Setiap jawapan diperuntukkan **satu** markah.*

1. Choose the correct statement to define Information and Communication Technology (ICT).

*Pilih pernyataan yang paling tepat untuk mendefinisikan Teknologi Maklumat dan Komunikasi (ICT).*

- A. Information and Communication Technology is composed of three main components of a computer, Internet and networking.

*Teknologi Maklumat dan Komunikasi (ICT) terdiri daripada tiga komponen utama iaitu komputer, internet dan rangkaian.*

- B. Information and Communication Technology (ICT) is a technology used by people to improve their lives.

*Teknologi Maklumat dan Komunikasi (ICT) adalah teknologi yang yang digunakan oleh manusia untuk meningkatkan kehidupan mereka.*

- C. Information and Communication Technology (ICT) is a technology that is needed to process the information using electronic equipment and software applications to transfer, store, send and receive data.

*Teknologi Maklumat dan Komunikasi (ICT) adalah satu teknologi yang diperlukan untuk memproses maklumat menggunakan peralatan elektronik dan perisian aplikasi untuk memindah, menyimpan, menghantar dan menerima data.*

- D. Information and Communication Technology (ICT) is any communication facilities and computer-based applications.

*Teknologi Maklumat dan Komunikasi (ICT) adalah sebarang komunikasi dan kemudahan aplikasi berasaskan komputer.*

2. Table 1 shows security measures to overcome computer threats

*Jadual 1 menunjukkan langkah keselamatan untuk mengatasi ancaman komputer*

X	Human aspects <i>Aspek kemanusiaan</i>
Y	Firewall <i>Firewall</i>
Z	Cryptography <i>Kriptografi</i>

Table 1  
*Jadual 1*

Based on Table 1, match the security measures with the following statements by writing **X**, **Y** or **Z**

*Berdasarkan Jadual 1, padankan langkah keselamatan dengan pernyataan berikut dengan menulis X, Y atau Z*

- (i) To function in a network environment to prohibit unauthorized access to your computer via the Internet.

*Berfungsi dalam rangkaian bagi menghalang capaian kepada komputer melalui Internet secara tidak sah.*

- (ii) As a security measure, make sure a computer room is always locked.

*Sebagai langkah keselamatan, pastikan bilik komputer sentiasa berkunci*

3. Write **True or False** for the following statement

*Tuliskan **Benar atau Palsu** pada pernyataan berikut*

Anti Spyware is a program to scan and remove virus from computer system.

*Anti Spyware adalah satu program untuk mengimbas dan membuang virus dari sistem komputer.*

4. Match the statements (a) and (b) with the terminologies in Table 2.

*Padankan kenyataan (a) dan (b) dengan istilah dalam Jadual 2.*

Malicious code
Theft
Fraud

Table 2  
*Jadual 2*

- a) Agent X broke into Defense Department computer Room of USA Government and download certain data to sell to the Russian secret agents.  
*Agen X telah menceroboh masuk ke bilik komputer Jabatan Pertahanan Amerika Syarikat dan memuat turun data untuk dijual kepada Agen Rahsia Rusia.*
- b) A student from China created a program and spread it through the Internet to attack the United States Department of Defense computer system.  
*Seorang pelajar dari Negara China telah mencipta satu program dan menyebarkannya melalui internet untuk menyerang sistem komputer Jabatan Pertahanan Amerika Syarikat.*

5. One character represents ..... bit.

*Satu karakter mewakili ..... bit*

6. Figure 1 shows a hierarchy in data measurement unit.

*Rajah 1 menunjukkan susunan dalam unit pengukuran data.*

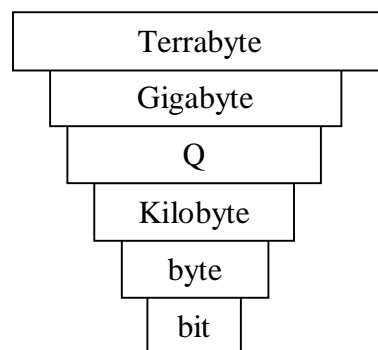

Figure 1  
*Rajah 1*

State Q

*Nyatakan Q*

7. Figure 2 shows two computer devices.

*Rajah 2 menunjukkan dua peranti komputer*



**P**



**Q**

Figure 2  
*Rajah 2*

Based on Figure 2, identify output device.

*Berdasarkan Rajah 2, kenalpasti peranti output*

8. **ASCII** stands for .....

*ASCII adalah singkatan kepada.....*

9. State whether the below matching is **True** or **False**  
*Nyatakan sama ada padanan di bawah **Benar** atau **Palsu***

Figure 3 shows a computer motherboard.

*Rajah 3 menunjukkan sebuah papan induk komputer.*

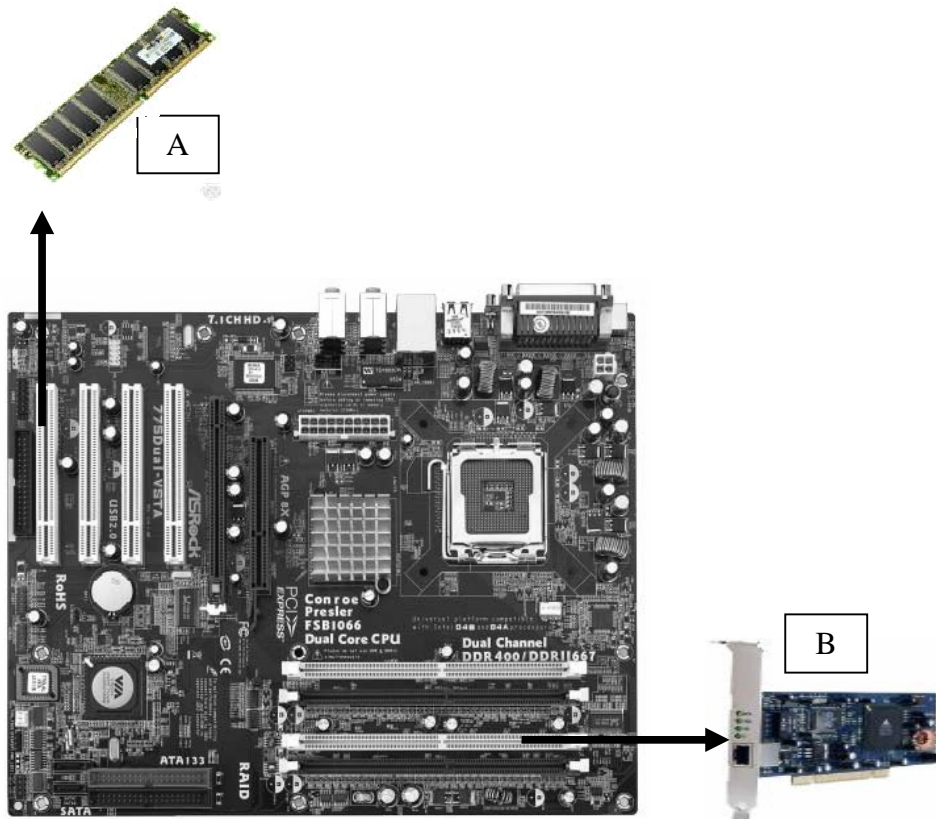

Figure 3  
*Rajah 3*

Based on Figure 3,  
*Berdasarkan Rajah 3,*

i) Matching A  
*Padanan A*

ii) Matching B  
*Padanan B*

10. State whether the following statement is **True or False**.

*Nyatakan sama ada pernyataan berikut **Benar atau Palsu**.*

Figure 4 shows the commands of network testing connection

*Rajah 4 menunjukkan arahan dalam menguji sambungan rangkaian*

```

C:\Documents and Settings\TEMP>ping 10.118.203.50

Pinging 10.118.203.50 with 32 bytes of data:

Reply from 10.118.203.50: bytes=32 time<1ms TTL=64
Reply from 10.118.203.50: bytes=32 time<1ms TTL=64
Reply from 10.118.203.50: bytes=32 time<1ms TTL=64
Reply from 10.118.203.50: bytes=32 time<1ms TTL=64

Ping statistics for 10.118.203.50:
    Packets: Sent = 4, Received = 4, Lost = 0 (0% loss),
    Approximate round trip times in milli-seconds:
        Minimum = 0ms, Maximum = 0ms, Average = 0ms
  
```

Figure 4

*Rajah 4*

The above commands show that the network testing does not work.

*Arahan di atas menunjukkan bahawa rangkaian yang diuji tidak berfungsi.*

11. Table 3 shows the function of a communication device used in the network.

*Jadual 3 menunjukkan fungsi satu peranti komunikasi yang digunakan dalam rangkaian.*

Network Communication Function <i>Fungsi Komunikasi Rangkaian</i>
<ul style="list-style-type: none"> <li>• Used for connecting wired computers or device on a Local Area Network (LAN) <i>Digunakan untuk menyambung komputer dengan kabel atau peranti pada Rangkaian Kawasan Setempat (LAN)</i></li> <li>• Provides a common connection point for nodes on a star network. <i>Menyambung nod-nod dalam rangkaian bintang</i></li> </ul>

Table 3

*Jadual 3*

Based on Table 3, state the name of communication device.

*Berdasarkan Jadual 3, nyatakan nama peranti komunikasi itu.*

12. Table 4 shows the information about the network communication technology

*Jadual 4 menunjukkan pernyataan berkaitan teknologi komunikasi rangkaian*

A	open for Public <i>terbuka untuk umum</i>
B	limited for employee only <i>hanya terhad untuk pekerja</i>
C	limited for employee and authorized outside user <i>terhad untuk pekerja dan pengguna luar yang sah</i>

Table 4  
*Jadual 4*

Based on Table 4, write **A**, **B** or **C** for the following type of network communication technology :

*Berdasarkan Jadual 4, tulis A, B atau C bagi jenis teknologi komunikasi rangkaian berikut:*

(i) Internet

*Internet*

(ii) Extranet

*Extranet*

13. Figure 5 shows two types of transmission media

*Rajah 5 menunjukkan dua jenis media penghantaran*

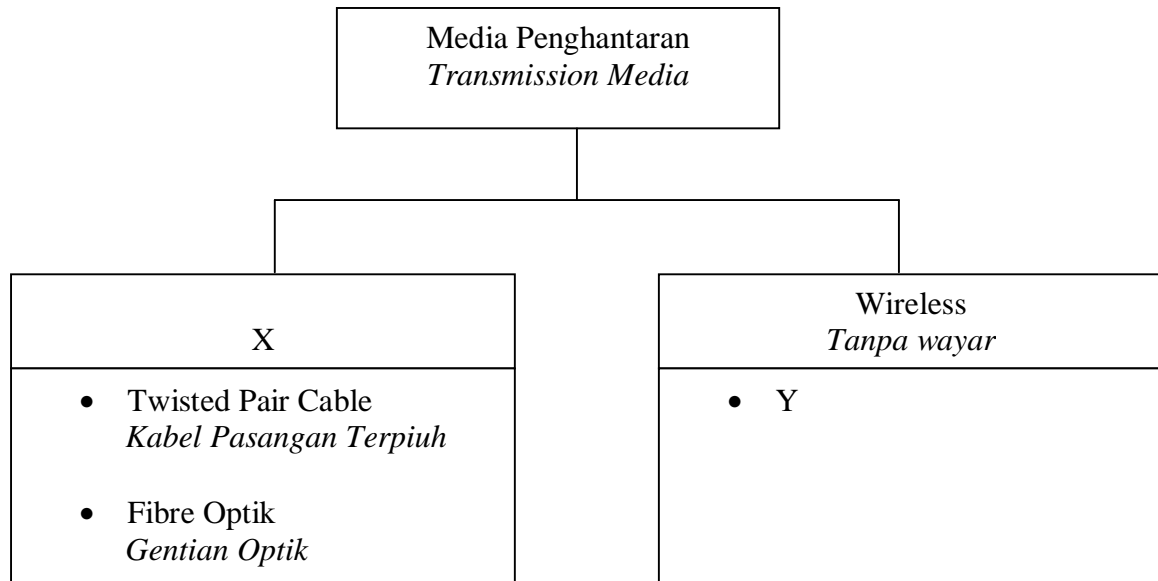

Figure 5  
*Rajah 5*

Based on Figure 5,

*Berdasarkan Rajah 5,*

- (i) Name X  
*Namakan X*
- (ii) State Y  
*Nyatakan Y*

14. State whether the following statements is **True** or **False**

*Nyatakan sama ada pernyataan berikut **Benar** atau **Palsu***

- i) A video that combines audio, graphics and animation is still considered as a non-linear multimedia content since the user is a passive receiver of the content..

*Video yang menggabungkan audio, grafik, dan animasi masih disebut sebagai kandungan multimedia tidak sejajar selagi pengguna menjadi penerima pasif.*

- ii) Multimedia is a computer technology that displays information using a combination of full-motion video, animation, sounds, graphics and text with high degree of user interaction

*Multimedia adalah teknologi komputer yang menayangkan maklumat yang menggabungkan video, animasi, bunyi, grafik dan teks yang menarik perhatian pengguna.*

15. Table 5 shows a multimedia production team role.

*Jadual 5 dibawah menunjukkan tugas-tugas pasukan multimedia.*

Member	Role
Project Manager <i>Pengurus Projek</i>	Define the scope of project and discuss with the client, search for financial resources, equipment and facilities. <i>Mengenalpasti skop project dan berbincang dengan pelanggan, mendapatkan peruntukan kewangan, peralatan dan kemudahan.</i>
X	Decide on the best educational strategies and practices to present the information. <i>Membuat keputusan strategi dan mempersembahkan maklumat.</i>
Y	Research and provide on the content of a multimedia program . <i>Kajian dan menyediakan kandungan program multimedia</i>
Graphic Artist <i>Grafik Artis</i>	Develop the graphic elements of the program such as backgrounds, buttons, photo collages, 3D objects, logos and animation. <i>Membangunkan elemen grafik seperti latar belakang, butang, koleksi gambar, objek 3D logo dan animasi</i>

Table 5  
*Jadual 5*

Based on Table 5, Name

*Berdasarkan jadual 5, Namakan*

a) X :

b) Y:

16. Figure 6 shows web editor interface

*Rajah 6 menunjukkan antaramuka suntingan web.*



```
File Edit View Help
<!DOCTYPE html PUBLIC "-//W3C//DTD XHTML 1.0 Transitional//EN" "http://www.
<html xmlns="http://www.w3.org/1999/xhtml">
<head>
<meta http-equiv="Content-type" content="text/html; charset=UTF-8" />
<meta name="keywords" content="Firefox; security; XSS; Jikto; Script blocki
<meta name="description" content="NoScript for Firefox pre-emptively blocks
<meta name="category" content="software,internet,development,downloads" />
<title>NoScript - JavaScript/Java/Flash blocker for a safer Firefox experie
<link rel="shortcut icon" href="/favicon.ico" type="image/x-icon" id="icon"
<link rel="alternate" type="application/rss+xml" title="NoScript RSS Feed"
<link rel="stylesheet" type="text/css" href="http://software.information.c
<style type="text/css">
.maonly { display: none; }
</style>
<script type="text/javascript">
var r = 0;
if (typeof window.addEventListener == "function")
  window.addEventListener("DOMContentLoaded",
    function() {
      var i = document.getElementById("icon");
      var h = i.parentNode;
      var i2 = i.cloneNode(false);
      i2.href = "noscript.ico";
      h.replaceChild(i2, i);
    }
  );
</script>
</html>
```

Figure 6

*Rajah 6*

Based on Figure 6,

*Berdasarkan Rajah 6,*

(a) Name the type of web editor software used.

*Namakan jenis perisian suntingan web yang digunakan.*

(b) Give one example of web editor in (a).

*Berikan satu contoh perisian suntingan web di (a).*

17. The lowest level of programming language is

*Bahasa pengaturcaraan aras terendah ialah*

A. BASIC

*BASIC*

B. Natural language

*Bahasa Tabii*

C. Machine language

*Bahasa Mesin*

D. Assembly language

*Bahasa Penghimpun*

18. State whether the following statement is **True** or **False**.

*Nyatakan sama ada pernyataan berikut **Benar** atau **Palsu**.*

- i) Programmers must convert an assembly language program into machine language before the computer can run or execute the program.

*Pengaturcara mesti menukar program bahasa penghimpun ke bahasa mesin sebelum komputer dapat melaksanakan program.*

- ii) A translator is a form of hardware that translates a program into the language that the computer can understand.

*Penterjemah ialah satu bentuk perkakasan yang menterjemahkan sebuah program ke dalam bahasa yang dapat difahami oleh komputer.*

19. Complete the following statements by filling in the blanks:

*Isikan ruang kosong untuk melengkapkan pernyataan berikut:*

The process of detecting, locating and correcting logic errors is called \_\_\_\_\_.

*Proses mengesan, mencari dan memperbaiki kesalahan logik disebut \_\_\_\_\_.*

20. Figure 7 shows part of programming code Total Parking Charges.

*Rajah 7 menunjukkan sebahagian daripada kod atur cara Total Parking Charges.*

```
Private Sub calculate_Click()  
Dim Hour, Minute As Integer  
Dim Total As Single  
  
msg = "Total Parking Charges is "  
TimeEntry = ((Total1 * 60) + Total2) / 60  
    lblCharges.Caption = TimeEntry  
If TimeEntry <= 0.5 Then  
    lblCharges.Caption = msg & "RM0.20"  
ElseIf TimeEntry > 0.5 AND TimeEntry <= 1 Then  
    lblCharges.Caption = msg & "RM0.50"  
ElseIf TimeEntry > 1 AND TimeEntry <= 1.5 Then  
    lblCharges.Caption = msg & "RM1.50"  
ElseIf TimeEntry > 1.5 Then  
    jb = 0.7 + (TimeEntry * 0.8)  
    lblCharges.Caption = msg & "RM" & jb  
End If  
  
End Sub
```

Figure 7  
*Rajah 7*

Based on 7 figure, state one :

*Berdasarkan rajah 7, nyatakan satu :*

- i. Variable :  
*Pembolehubah:*
- ii. Logical Operator:  
*Operator Logik:*

21. State whether the following statement is **True** or **False**.

*Nyatakan sama ada pernyataan berikut **Benar** atau **Palsu**.*

The Implementation Phase in the system development refers to the written material generated throughout all the phases of the system development.

*Fasa Pelaksanaan dalam pembinaan sistem merujuk kepada bahan bertulis yang dihasil sepanjang fasa pembinaan sistem.*

22. Figure 8(a) shows a table in a database and Figure 8(b) shows the output of data manipulation in the table Query.

*Rajah 8(a) menunjukkan satu jadual dalam pangkalan data dan Rajah 8(b) menunjukkan hasil manipulasi data tersebut dalam jadual Query.*

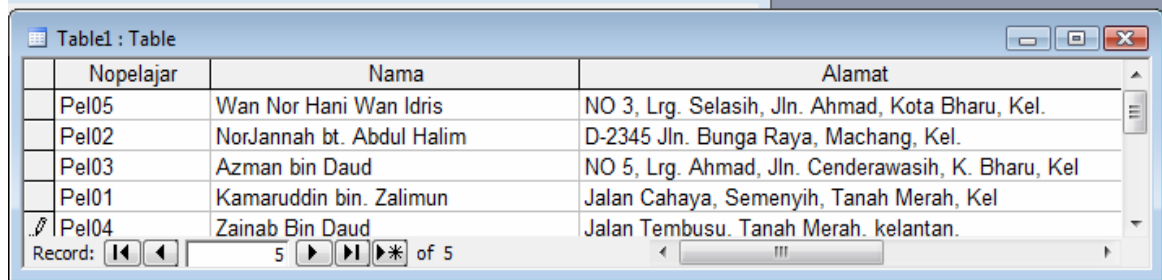

Nopelajar	Nama	Alamat
Pel05	Wan Nor Hani Wan Idris	NO 3, Lrg. Selasih, Jln. Ahmad, Kota Bharu, Kel.
Pel02	NorJannah bt. Abdul Halim	D-2345 Jln. Bunga Raya, Machang, Kel.
Pel03	Azman bin Daud	NO 5, Lrg. Ahmad, Jln. Cenderawasih, K. Bharu, Kel
Pel01	Kamaruddin bin. Zalimun	Jalan Cahaya, Semenyih, Tanah Merah, Kel
Pel04	Zainab Bin Daud	Jalan Tembusu. Tanah Merah. kelantan.

Figure 8(a)  
*Rajah 8(a)*



Nopelajar	Nama	Alamat
Pel01	Kamaruddin bin. Zalimun	Jalan Cahaya, Semenyih, Tanah Merah, Kel
Pel02	NorJannah bt. Abdul Halim	D-2345 Jln. Bunga Raya, Machang, Kel.
Pel03	Azman bin Daud	NO 5, Lrg. Ahmad, Jln. Cenderawasih, K. Bharu, Kel
Pel04	Zainab Bin Daud	Jalan Tembusu, Tanah Merah, kelantan.
Pel05	Wan Nor Hani Wan Idris	NO 3, Lrg. Selasih, Jln. Ahmad, Kota Bharu, Kel.

Figure 8(b)  
*Rajah 8(b)*

Identify the basic operation of data manipulation that has been done.

*Kenalpasti satu operasi asas dalam manipulasi data yang telah dilakukan .*

23. The following is a text on system development for a company.

*Berikut adalah teks tentang pembinaan sistem untuk sebuah syarikat.*

Ahmad is a system analyst for Atira Company. His company has decided to rebuild the company's Information System. He has been asked to handle the work. For a start he has planned to study how the current system works by reviewing old documents. In order to determine what users want he has decided to do some interviews with the users...

*Ahmad ialah seorang juruanalisa sistem bagi Syarikat Atira. Syarikatnya telah bercadang untuk membina semula sistem maklumat syarikat. Beliau telah ditugaskan untuk menguruskan kerja tersebut. Sebagai permulaan beliau bercadang untuk melihat keadaan sistem sediaada dengan meneliti dokumen-dokumen lama. Untuk menentukan kehendak pengguna beliau bercadang menjalankan temuramah dengan pengguna-pengguna...*

Based on the statement above ,

*Berdasarkan pernyataan di atas,*

State the Phase of System development that takes place in the scenario.

*Nyatakan fasa pembinaan sistem yang berlaku di dalam situasi di atas.*

24. Figure 9 shows the interrelation between Information System components.

*Rajah 9 menunjukkan hubungan di antara komponen-komponen sistem maklumat.*

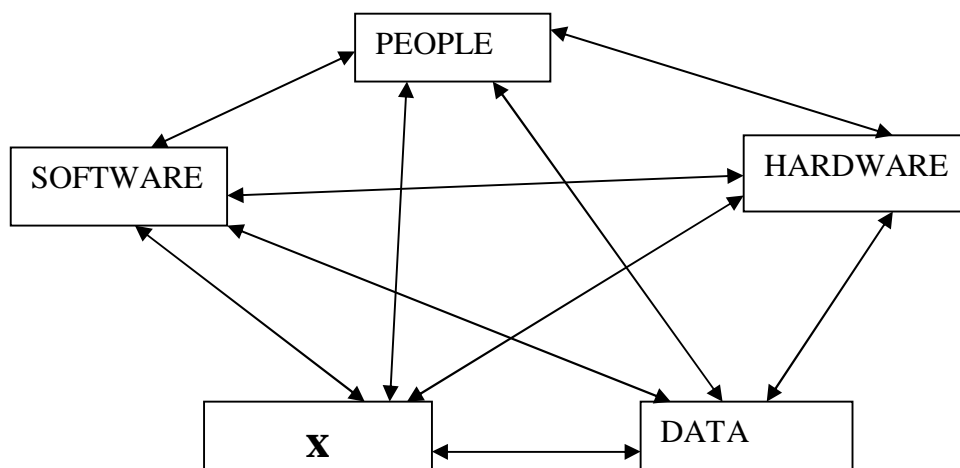

Figure 9  
Rajah 9

Identify X.

*Kenalpasti X.*

25. Figure 10 shows two tables in a database.

*Rajah 10 menunjukkan dua jadual dalam pangkalan data.*

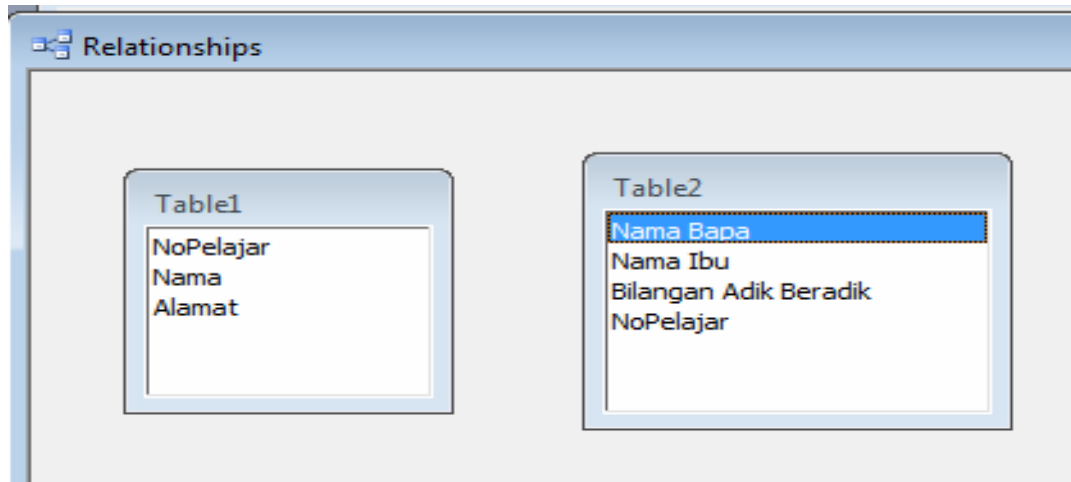

Figure 10  
*Rajah 10*

a) Identify a field name from both tables to make a relationship.

*Kenalpasti satu medan daripada kedua-dua jadual bagi mewujudkan hubungan.*

b) State the total number of fields in Table2

*Nyatakan bilangan medan dalam Jadual2*

**Section B*****Bahagian B***

[ 20 marks ]

[ 20 markah ]

This section consists of **five** questions. Answer **all** questions.

*Bahagian ini mengandungi lima soalan. Jawab semua soalan.*

26. The following is a statement about computer ethics.

*Berikut adalah pernyataan tentang etika komputer*

Ali has been appointed by his teacher to help other teachers to key in the test score into school HC3 Examination Program. Without his teacher knowledge he had changed his ICT's subject marks from 40% to 75%. As a result of the actions he has successfully passed the subject.

*Ali telah dilantik oleh gurunya untuk membantu guru-guru memasukkan markah peperiksaan ke Program Peperiksaan HC3 sekolahnya. Tanpa pengetahuan gurunya beliau telah mengubah markah subjek ICTnya dari 40% ke 75%. Hasil dari perbuatan tersebut beliau telah lulus dengan cemerlang subjek tersebut.*

Based on the statement above,

*Berdasarkan pernyataan di atas,*

(a) What is the type of misconduct based on the underlined phase above.

*Apakah jenis kesalahan yang dilakukan berdasarkan pernyataan bergaris di atas.*

*Definisikan jenis kesalahan tersebut.*

[2 marks]

[2 markah]

(b) Explain the negative impact done by Ali towards the school.

*Terangkan kesan negatif perbuatan yang dilakukan Ali kepada sekolah.*

[2 marks]

[2 markah]

27. Figure 11 shows a machine cycle.

*Rajah 11 menunjukkan satu kitaran mesin.*

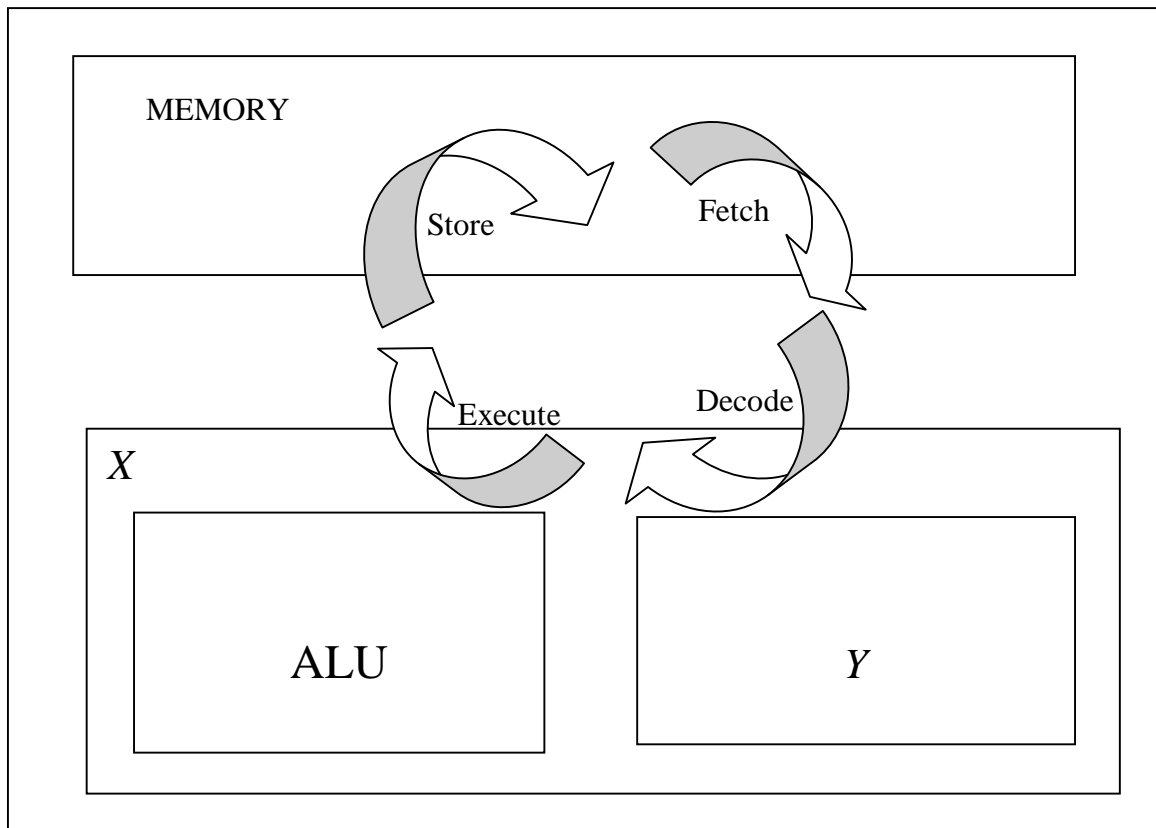

Figure 11

*Rajah 11*

Based on Figure 11,

*Berdasarkan Rajah 11,*

(a) Name :

*Namakan :*

(i) X

(ii) Y

[ 2 marks ]

[2 markah]

- (b) State two functions of X.

*Nyatakan dua fungsi X.*

[ 2 marks ]

[2 markah]

28. Figure 12 shows a sketch of a Computer Laboratory.

*Rajah 12 menunjukkan lakaran sebuah makmal komputer.*

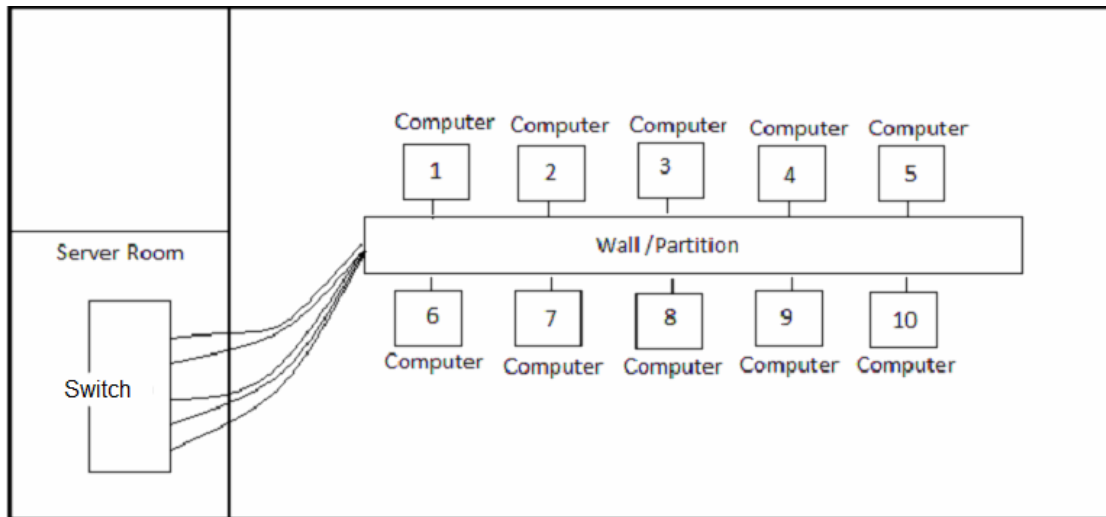

Figure 12

*Rajah 12*

Based on Figure 12,

*Berdasarkan Rajah 12,*

- (a) Identify the topology used and give a reason.

*Kenalpasti topologi yang digunakan dan beri alasan.*

[ 2 Marks ]

[2 Markah]

- (b) State two differences between the topology above with the ring topology.

*Nyatakan dua perbezaan antara topologi di atas dengan topologi cincin.*

[ 2 Marks ]

[2 Markah]

29. Figure 13(a) and 13(b) show flow charts of two programs.

Rajah 13(a) dan Rajah 13(b) menunjukkan carta alir bagi dua program.

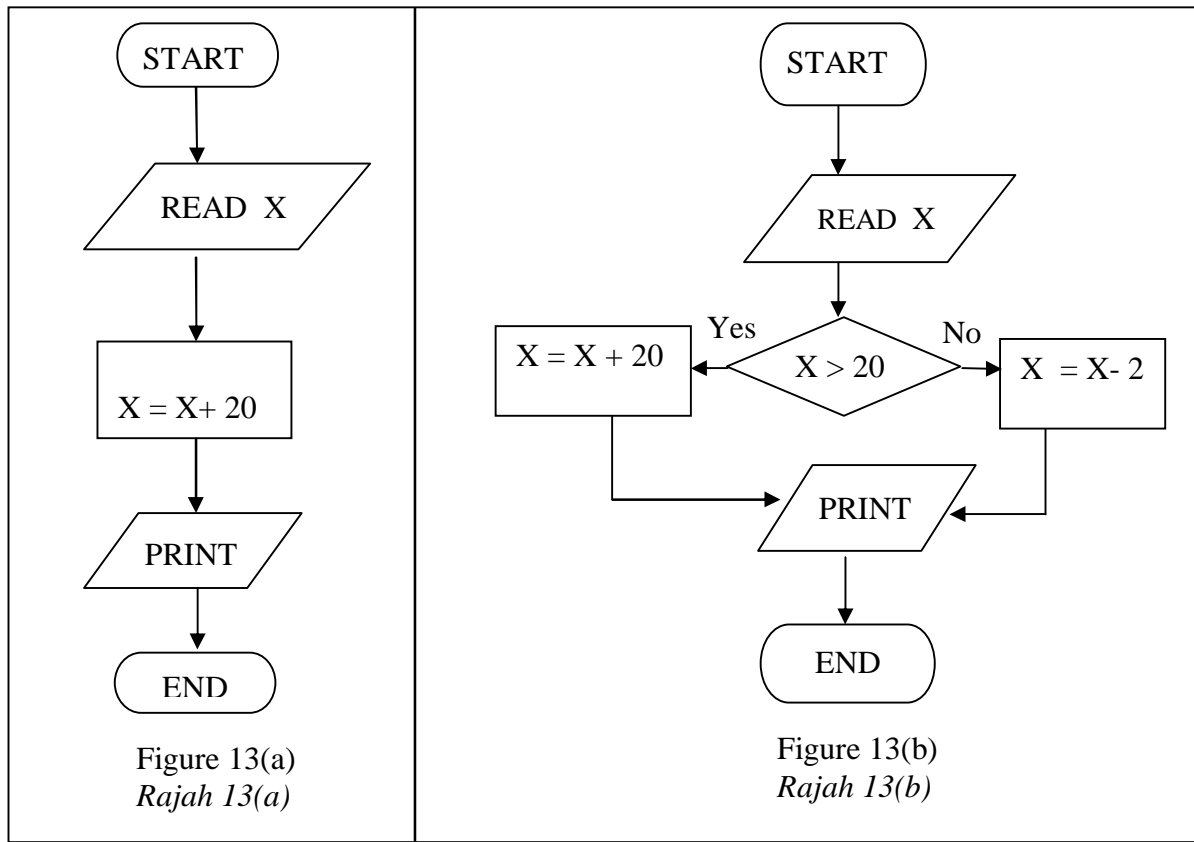

Based on Figure 13(a) and Figure 13(b),

Berdasarkan Rajah 13(a) dan Rajah 13(b),

(a)

Input Item	Input Data
X	12

Table 6  
Jadual 6

Write the Output for the flowchart in figure 13(a) and 13(b) based on the Input Data in the Table 6.

Tuliskan output untuk carta alir dalam Rajah 13(a) dan 13(b) berdasarkan data input di dalam Jadual 6.

(i) 13(a)

(ii) 13(b)

[2marks]

(b) What control structure is used in Figure 13(b). Give a reason.

Apakah struktur kawalan yang digunakan dalam Rajah 13(b). Berikan alasan.

[2 marks]

30. Figure 14(a) and Figure 14(b) show two tables created in the TechCom Information System at TechCom Sdn Bhd.

*Rajah 14(a) dan Rajah 14(b) menunjukkan dua jadual yang dibina di dalam sistem maklumat TechCom di TechCom Sdn Bhd.*

	Customer ID	Name	Address	Telephone No
+	C001	Abu Samad	Wakaf Bharu	012-1234567
+	C010	Wan Nazir	Kota Bharu	013-9012345
+	C078	Rafidah	Pasir Mas	019-2334455
+	C990	Radhuan	Bachok	017-2345687

Figure 14(a)  
*Rajah 14(a)*

	Service ID	Customer ID	Date of Service	Service Description
	S002	C001	17-Jul-07	change HDD
	S012	C078	12-Jun-07	reinstall OS
	S014	C010	12-Jun-07	replace battery
	S111	C010	17-Jul-07	change HDD
	S222	C078	20-Jul-07	replace battery
	S223	C010	20-Jul-07	printer servicing

Figure 14(b)  
*Rajah 14(b)*

Based on Figure 14(a) and Figure 14(b),

*Berdasarkan Rajah 14(a) dan Rajah 14(b),*

- (a) State the primary key and foreign key fields in the Figure 14(b).

*Nyatakan medan kekunci primer dan kekunci asing pada Rajah B.*

[2 marks]  
[2 Markah]

- (b) State two the importance of the function of primary key.

*Nyatakan dua kepentingan fungsi kekunci primer.*

[2 marks]  
[2 Markah]

**Section C*****Bahagian C***

[14 marks]

*[14 markah]*

This section consists of **three** questions. Answer **two** questions only:

*Bahagian ini mengandungi tiga soalan. Jawab **dua** soalan sahaja:*

(i) **Question 31**, and

*Soalan 31, dan*

(ii) **Question 32** or **Question 33**.

*Soalan 32 atau Soalan 33.*

- 31 Figure 15 shows the part of Y phase of the project set up to produce a multimedia application in the form of non- linear interactivity.

*Rajah 15 menunjukkan sebahagian daripada fasa Y yang disediakan untuk menghasilkan satu projek aplikasi multimedia yang berbentuk interaktiviti tidak linear.*

Project Title <i>Tajuk Projek</i>	Mathematics Year 1 <i>Matematik Tahun 1</i>
Objective <i>Objektif</i>	produce a multimedia application for year 1 students in the learning of a simple mathematical operations involving adding, minus, multiply and divide numbers between 0 and 9.  <i>menghasilkan satu aplikasi multimedia untuk murid-murid tahun 1 dalam pembelajaran matematik mudah melibatkan operasi menambah, menolak, mendarab dan membahagi nombor-nombor di antara 0 hingga 9.</i>
Target <i>Sasaran</i>	Year 1 students <i>Murid Tahun</i>

Figure 15  
*Rajah 15*

Based on Figure 15,

*Berdasarkan Rajah 15,*

- (a) (i) Name Y phase

*Namakan Fasa Y*

- (ii) Based on your answer in (a) (i) specify a method used to identify problems and needs in developing multimedia applications.

*Berdasarkan jawapan anda dalam (a)(i), nyatakan satu kaedah yang digunakan untuk mengenalpasti masalah dan keperluan dalam membangunkan aplikasi multimedia tersebut.*

[2 marks]  
[2 markah]

- (b) Draw a storyboard for the first page that contains the project title and two elements of multimedia graphics and audio.

*Lakarkan satu papan cerita untuk halaman pertama yang mengandungi tajuk projek dan 2 elemen multimedia iaitu grafik dan audio.*

[5 marks]

32 The following is a text on computer crime in a Television station broadcasting.

*Berikut adalah teks mengenai jenayah computer di sebuah stesen siaran Television.*

*Aizat bertugas sebagai seorang penyunting di sebuah syarikat penerbitan rancangan television swasta.. Beliau menggunakan kepakarannya dalam bidang ICT untuk membuat suntingan terhadap rancangan-rancangan television tersebut bagi menjaga kualitinya sebelum disiarkan oleh stesen-stesen television. Tanpa kebenaran pihak syarikat tersebut Aizat telah membuat rakam salin terhadap rancangan television terbitan tersebut serta menjualnya di internet.*

*Aizat works as an editor in a private television broadcasting. He uses his expertise in ICT for editing the television programs in order to preserve the quality before they were broadcast by the television station. Without company's permission Aizat has made copies of the television programs and sell them via Internet.*

Based on the text:

*Berdasarkan teks itu:*

- (a) State the computer crime that has been done by Aizat.

*Nyatakan jenaya komputer yang telah dilakukan oleh Aizat.*

[1 marks]  
[1markah]

- (b) Explain the importance of Cyber Law to the editing company.

*Terangkan kepentingan Undang-undang Siber untuk Syarikat penerbitan tersebut.*

[2 marks]  
[2 markah]

- (c) Explain two ways from the human aspect to avoid the above crime.

*Terangkan DUA langkah dari aspek kemanusiaan untuk mencegah jenayah di atas.*

[4 marks]  
[4 markah]

33 Statement 1 below is about computer installation.

*Pernyataan 1 di bawah adalah berkaitan pemasangan komputer.*

Azrul who is an accounting student wants to buy a computer to be used at the university. In order to save the cost, he bought the computer components and assemble the components. After successfully installing the computer, then Azrul follows the steps below: -

Step 1 – formatting hard disk

Step 2 - Installing X Software

When finished installing X, Azrul needs to install the three other software to help him complete the assignment at the university.

- Software A - word processor
- Software B - Spreadsheet
- Software C – Presentation

*Azrul seorang pelajar perakaunan ingin membeli sebuah komputer untuk kegunaannya belajar di universiti. Untuk menjimatkan kos, beliau membeli komponen komputer dan memasang sendiri komponen tersebut menjadi sebuah komputer. Setelah berjaya memasang komputer, seterusnya Azrul mengikuti langkah-langkah di bawah :-*

*Langkah 1 - Menformat cakera keras*

*Langkah 2 - Memasang Perisian X*

*Setelah selesai memasang perisian X, Azrul perlu memasang tiga perisian di bawah untuk membantu beliau menyiapkan tugasan di universiti.*

- *Perisian A - Pemproses Perkataan*
- *Perisian B - Hambaran Elektronik*
- *Perisian C - Persembahan*

Statement 1

*Pernyataan 1*

Based on the Statement 1,

*Berdasarkan Pernyataan 1,*

i) Name the type of Software X and describe the function.

*Namakan jenis perisian X dan jelaskan fungsinya.*

[3 marks]

ii) Explain the use of Software B and C to Azrul so that he can complete his coursework in the university.

*Terangkan kegunaan perisian B dan C kepada Azrul untuk beliau menyiapkan kerja kursusnya di universiti.*

[4 marks]